

Carburetor WA-167-1

Description	Part #
Part Name	WA-167-1
Venturi (mm)	11.11
* Kit - Repair	K10-WAT
** Kit - Gasket/Diaphragm	D10-WAT
1 Body Assembly - Air Purge	5-2540
2 Body Assembly - Primer	--
3 * Ring - Screen Retainer	16-42
4 Ring - Shaft Retainer	16-73
5 +++ O' Ring - Idle Needle	--
6 +++ O' Ring - Power Needle	--
7 +++ O' Ring - Limiter Caps	--
8 Lever - Throttle	--
9 Cover - Metering Diaphragm	--
10 Cover - Fuel Pump	21-353
11 Cover - Primer	21-404
12 +++ Cap Kit (limiter)	--
13 Shaft Assembly - Throttle	30-1006
14 Valve - Throttle	34-93
15 Button - Fuel Shut-Off	--
16 Clip - Throttle Shaft	--
17 Swivel Kit	--
18 Hose Fuel Intake (with jet)	--
19 * Valve - Inlet Needle	82-75
20 Governor Kit	--
21 Nozzle Assembly - Check Valve	84-615
22 Seat Assembly - Check Valve	--
23 * Plug - Welch	88-171
24 * Plug - Welch or Cup	88-136
25 +++ Plug - Needle	--
26 ** Gasket - Fuel Pump	92-225
27 ** Gasket - Metering Diaphragm	92-251
28 ** Gasket - Circuit Plate	--
29 ** Diaphragm - Fuel Pump	95-118
30 ** Diaphragm - Circuit	--
31 ** Diaphragm - Surge Chamber	--
32 ** Diaphragm Ass'y - Metering	95-526
33 ** Diaphragm Ass'y - Primer	--
34 Screw - Throttle Valve	96-207
35 Screw - Lever Retainer	--
36 Screw - Metering Lever Pin	96-156
37 Screw - Fuel Pump Cover	96-166
38 Screw - Idle Adjust Kit	96-646
39 Screw - Circuit Plate	--
40 Screw - Swivel	--
41 Screw Ass'y - Metering Cover - [4]	96-578
42 Screw - Shaft Retainer Clip	--
43 Spring - Needle (power)	98-405
44 Spring - Needle (idle)	98-404
45 Spring - Metering Lever	98-350
46 Spring - Throttle Return	98-494
47 Spring - Primer Diaphragm	--
48 +++ Needle - Idle	102-284
49 +++ Needle - Power	102-597
50 Needle Kit	--
51 Washer - Cover Screw	--
52 +++ Washer - Idle Needle	--
53 +++ Washer - Power Needle	--

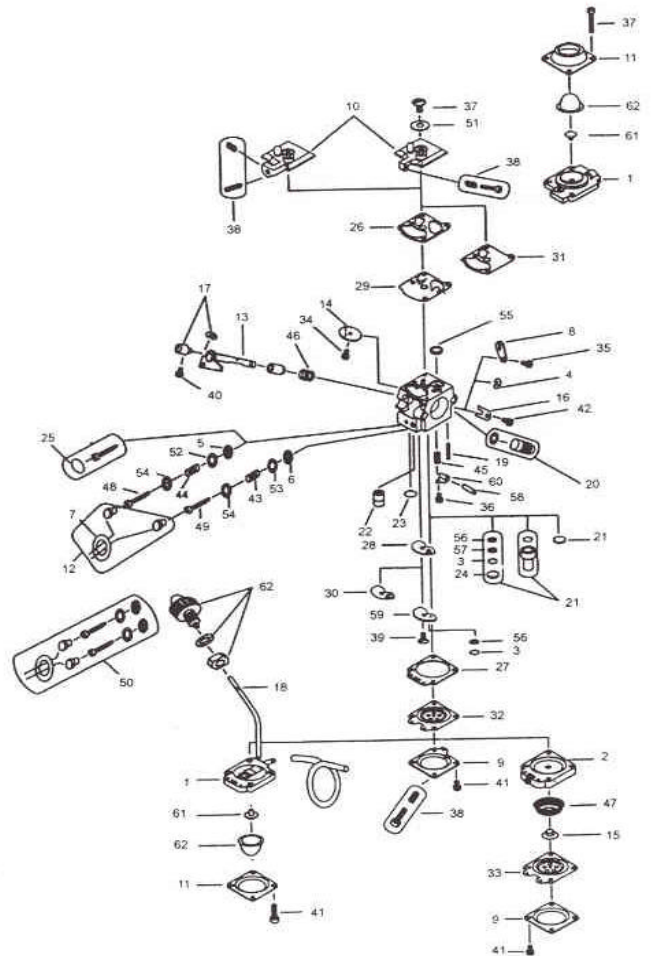

54 +++ Washer - Needle - [2]	--
55 * Screen - Fuel Inlet	140-70
56 * Screen - Check Valve	140-69
57 * Screen - Check Valve	--
58 Pin - Metering Lever	144-77
59 Plate - Circuit	--
60 * Lever - Metering	166-48
61 Valve - Check	176-64
62 Primer - Bulb	188-12